

	Litzenfarben	Colour of strands	Couleur des cordons
BK	schwarz	black	noir
WH	weiß	white	blanc
BU	blau	blue	bleu
YE	gelb	yellow	jaune
RD	rot	red	rouge
TR	transparent	transparent	transparent
BN	braun	brown	brun
GY	grau	grey	gris
GNYE	grün-gelb	green-yellow	vert-jaune
BKWH	schwarz-weiß	black-white	noir-blanc
GN	grün	green	vert
OG	orange	orange	orange
VT	violett	violet	violet
TQ	türkis	turquoise	turquoise

	Bedeutung der Kurzzeichen	Meaning of the symbols	Interprétation des symboles
B	Stecker	plug	fiche
C	Kondensator	condenser	condensateur
D	Funkentstördrossel	interference suppression inductance	inductance d'antiparasitage
E	Elektronik-Baustein	electronic unit	unité électronique
I	Induktionsspule	induction coil	bobine d'inductance
K	Klemme	terminal	borne
L	Licht	light	lumière
M	Motor	motor	moteur
O	Überlastschutz	overload cut-out	déclencheur de surintensité
R	Drehrichtungsumschalter	reversing switch	commutateur droite-gauche
S	Schalter	switch	interrupteur
U	Umschalter	change-over switch	commutateur
X	Elektronik-Element	electronic element	élément électronique

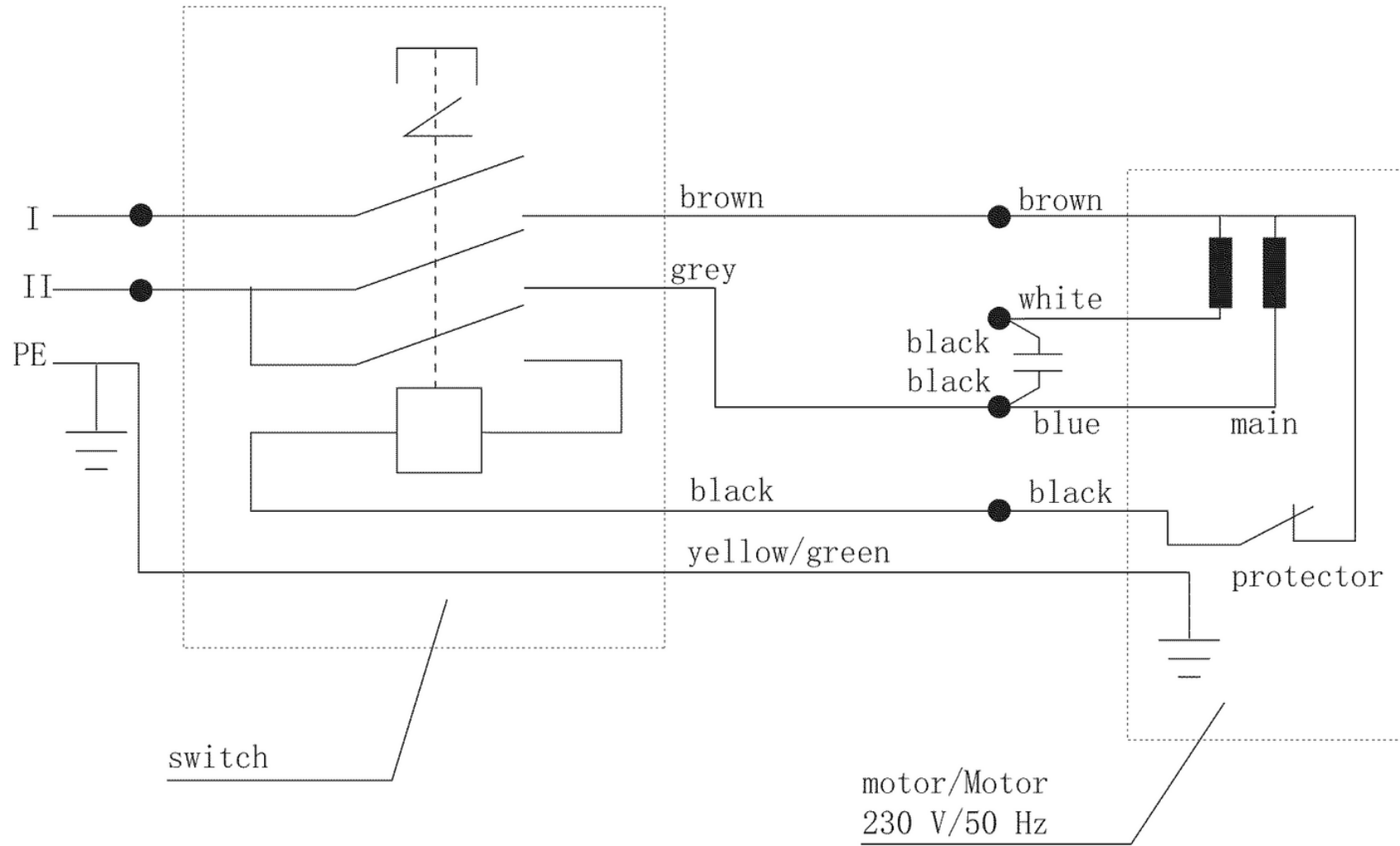

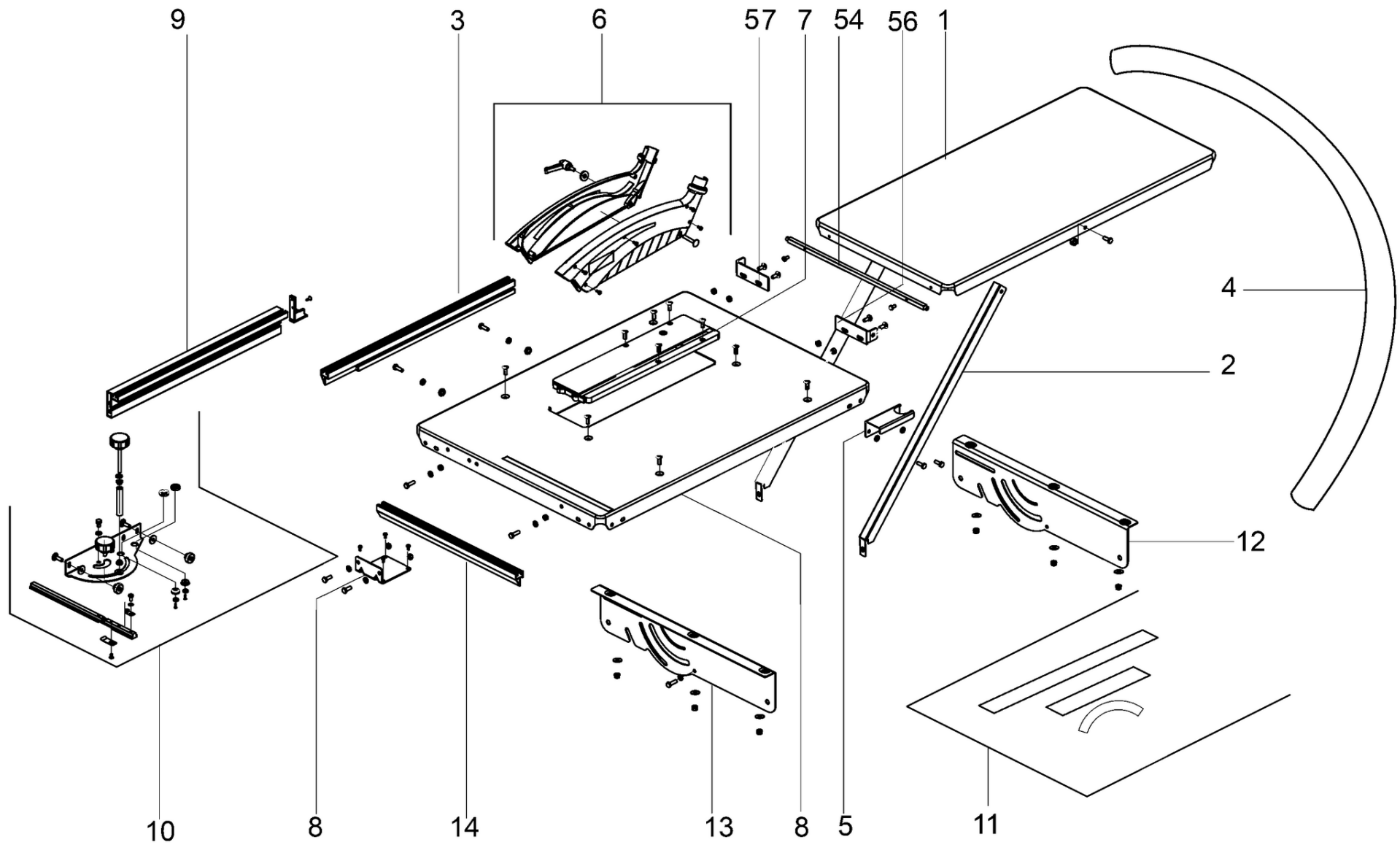

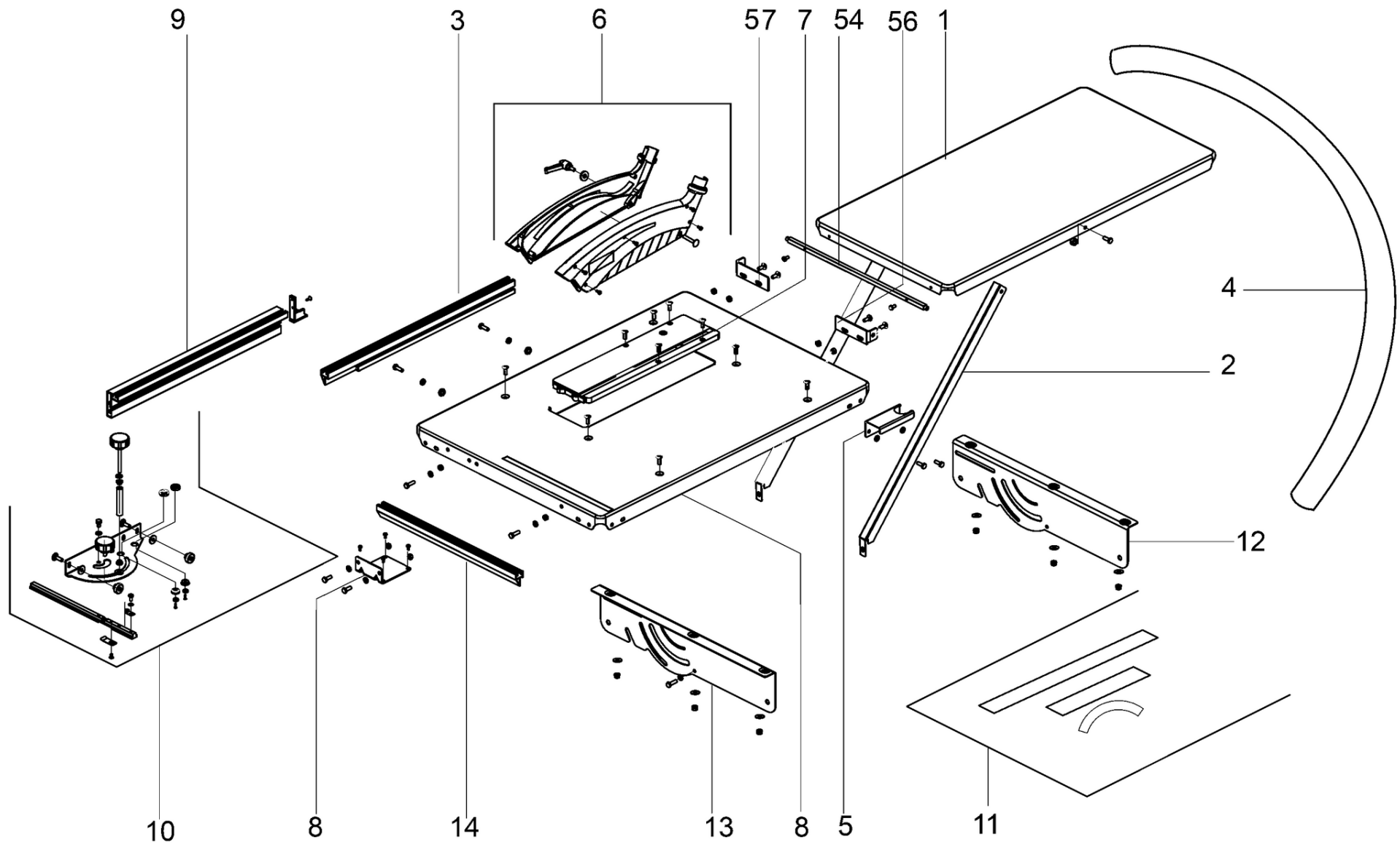

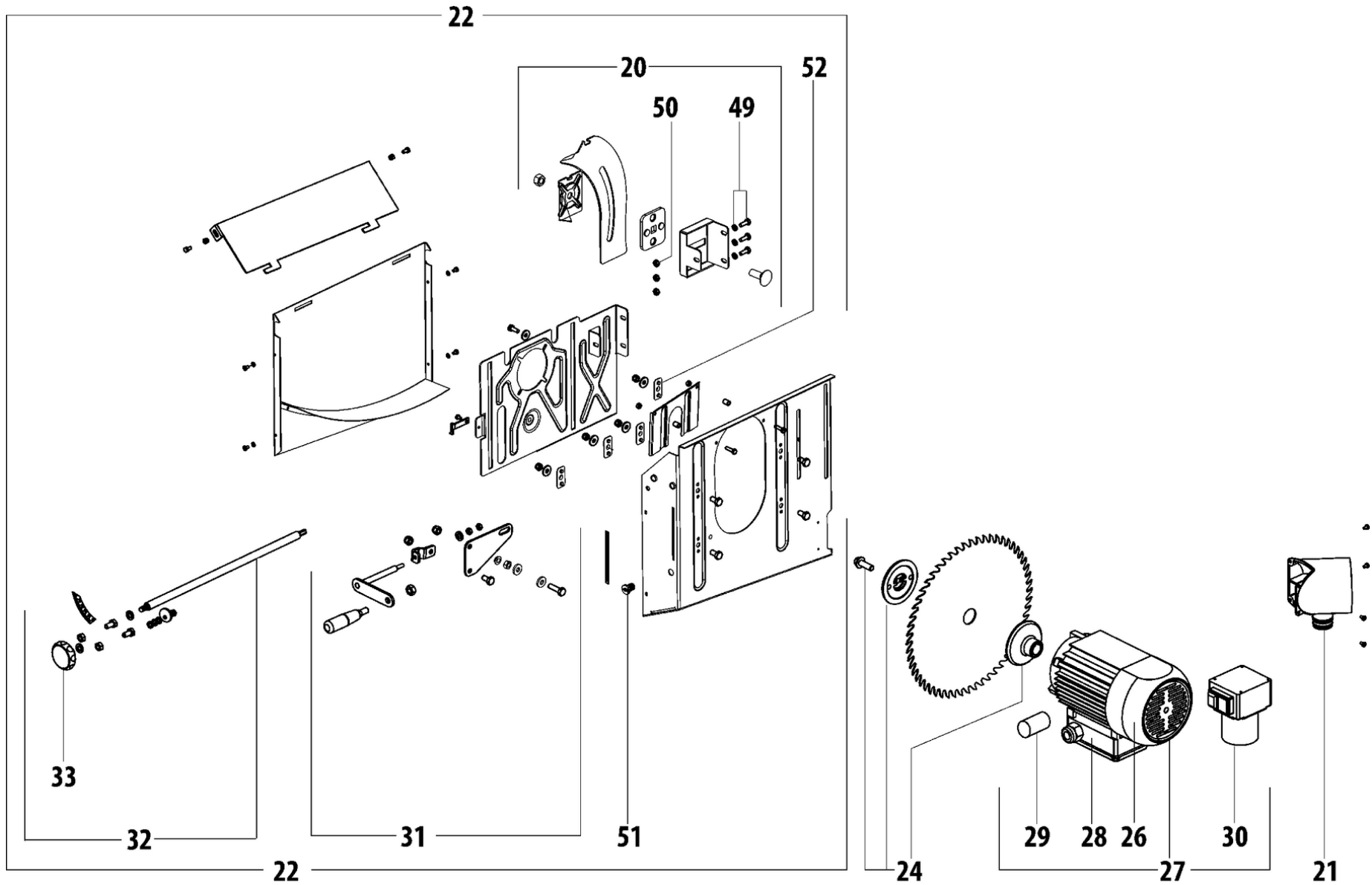

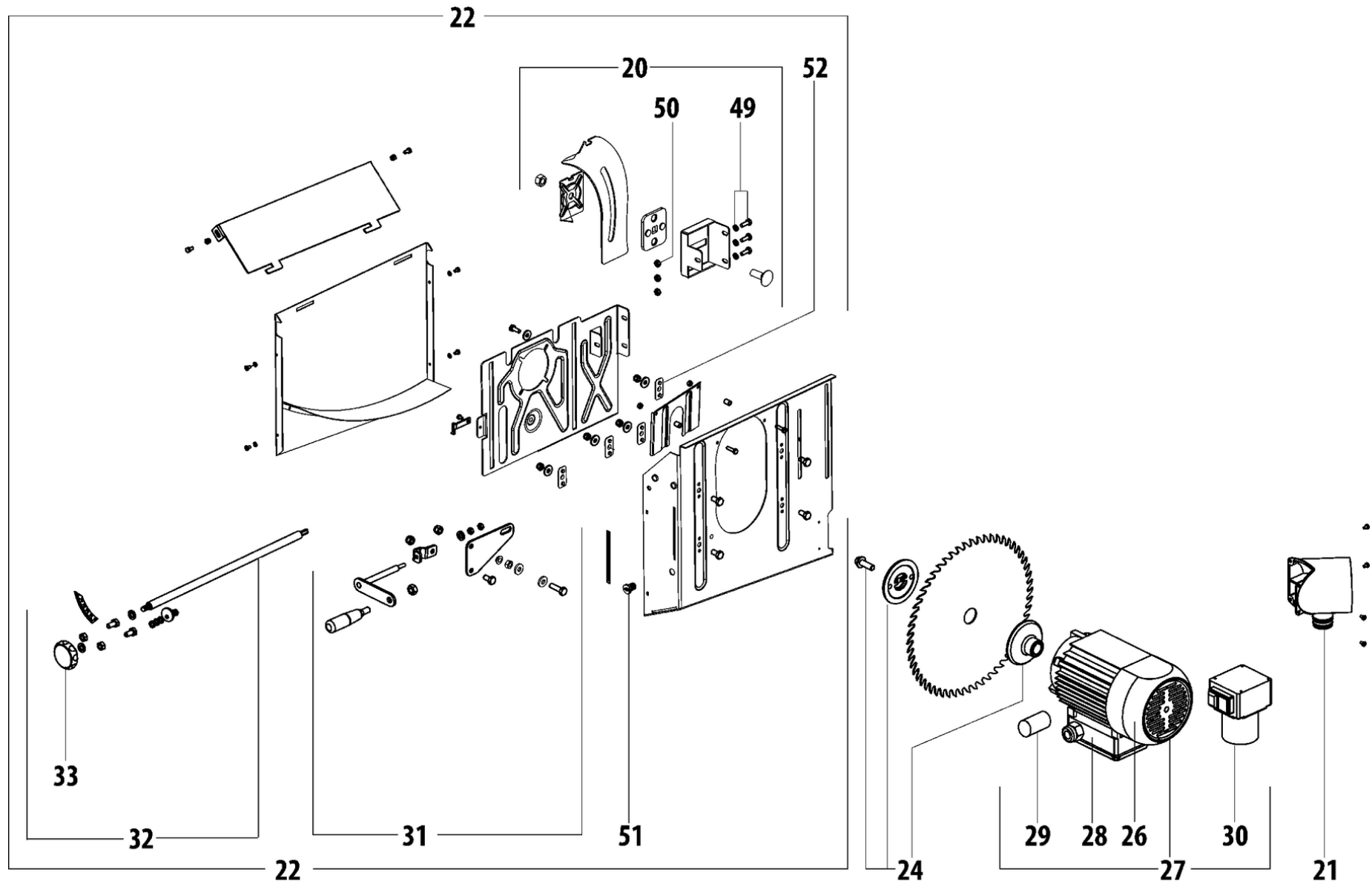

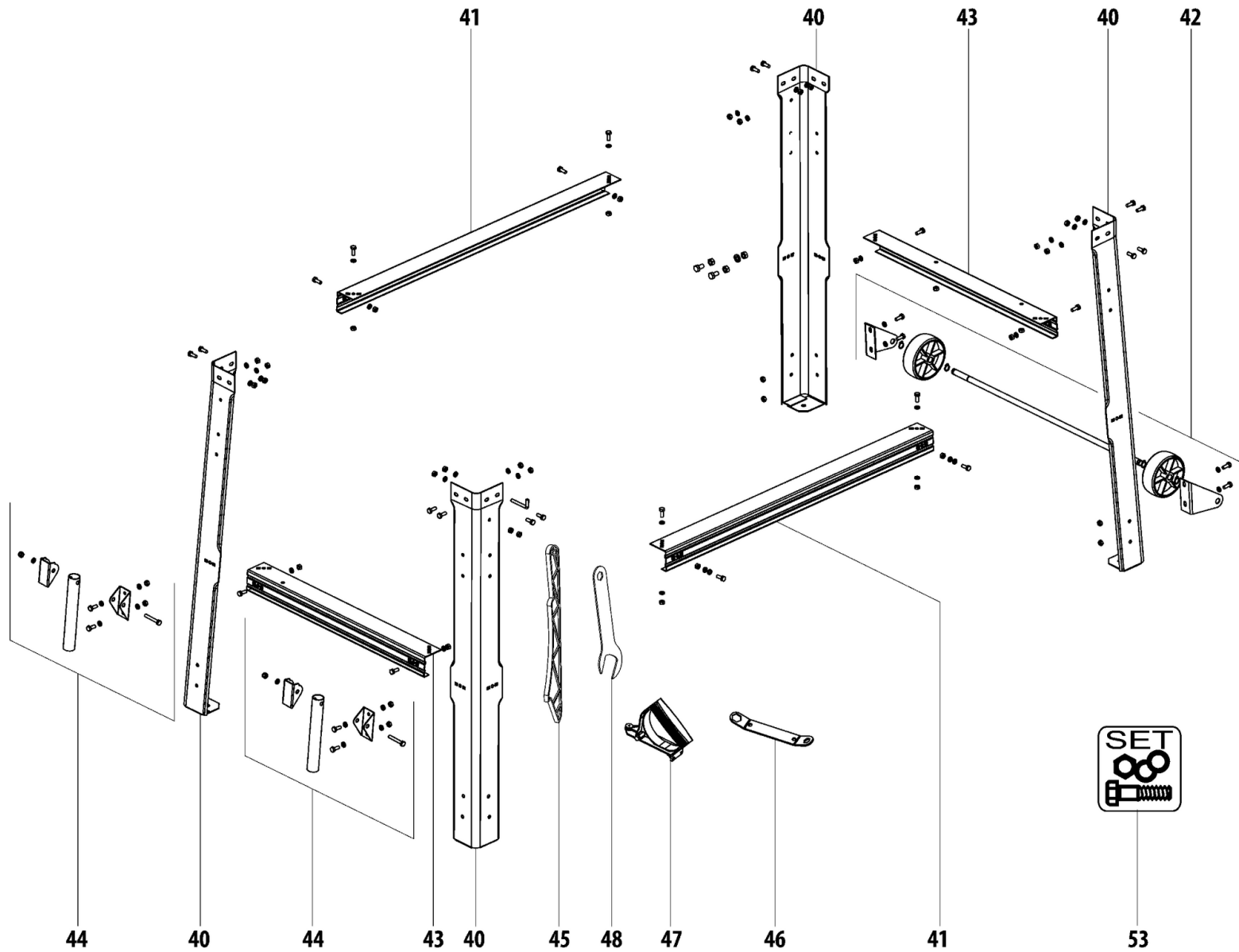

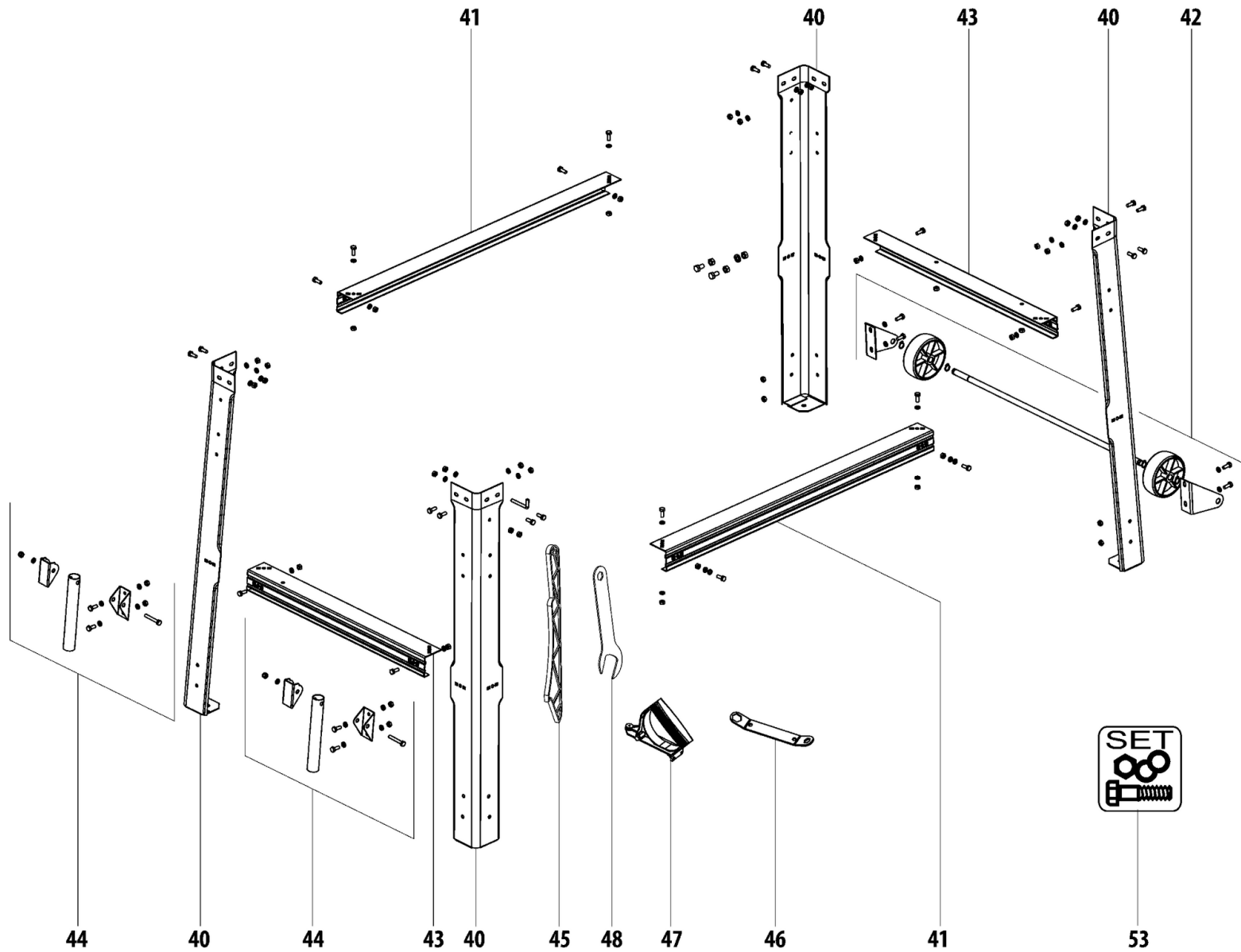

Posicion	Cantidad	Referencia	Descripcion	PG
1	1	339148330	Placa de mesa	35
2	2	339148340	Apoyo	20
3	1	1383689100	PIEZA GUIA LINKS /ET	20
4	1	7854158010	MANGUERA RDI 36,2X1500 PROFIL D	27
5	1	1382689123	SOPORTE DE MANGUERA ET	13
6	1	1010738543	PROTECCION	22
7	1	1381689138	SUPLEMENTO ET	19
8	1	1382689140	PLACA DE MESA ET	40
9	1	1383689151	PERFIL DE TOPE ET	26
10	1	1010689160	TOPE ANGULAR ET	27
11	1	1010689178	JUEGO DE ESCALA 3-TLG /ET	12
12	1	339136430	Chapa final detras	23
13	1	339136250	Chapa final Ergänzung fehlt in dieser Sp	23
14	1	1383689208	PIEZA GUIA VORNE /ET	20
20	1	341161620	Soporte	25
21	1	1381689227	MANGUITO DE ASPIRACION TKHS315C/M	19
22	1	343435390	CAJA DE VIRUTAS cpl.	46
24	1	1010689240	BLADE COLLAR ASSEMBLY ET	26
26	1	316094750	ALA DEL VENTILADOR CON CUBRE	20
27	1	316094730	Motor cpl.	62
28	1	316094740	CAJA cpl.	21
29	1	343255050	Condensador	26
30	1	8131689277	INTERRUPTOR SSK 230V 50Hz 10A ET	38
31	1	316055360	MANIVELA cpl.	23
32	1	316096780	RETENCION cpl.	21
33	1	7000028937	TUERCA M 8 (DIN 934) VERZINKT	13
40	4	1382689298	PIERNA ET	33
41	2	1382689301	BARRA R/L ET	28
42	1	1010689313	CARRO DE TRASPORTE TKHS315C ET	28
43	1	1382689328	BARRA V/H ET	26
44	1	1010689330	PASAMANOS (PAR) TKHS315C/M	20
45	1	343433180	Baston de empuje	15
46	1	1382689395	LLAVE SW 19-13	13
47	1	1388680470	PERFIL ROT	31
48	1	1392038481	LLAVE BL 3X43/15X145 SW 19X145	15
49	3	141110270	Tornillo exagonal	11
50	3	6209114230	Tuerca de brida	11
51	1	341006180	Casquillo	15
52	1	343434960	Corredera	11
53	1	316055370	Set Tornillos	21
54	1	343443700	Eje	20

Posicion	Cantidad	Referencia	Descripcion	PG
55	1	344113100	Pie de goma set	18
56	1	343443690	Soporte derecha	20
57	1	343443680	Soporte izquierda	20
1001	1	338506900	Placa de características	

2,2 WNB

