

Symbol	Bedeutung der Kurzzeichen	Meaning of the symbols
C	Kondensator	capacitor
E	Elektronik-Baustein	Electronic unit
M	Motor	Motor
S	Schalter	Switch
BK	Schwarz	Black
BN	Braun	Brown
BU	Blau	Blue
GY	Grau	Grey

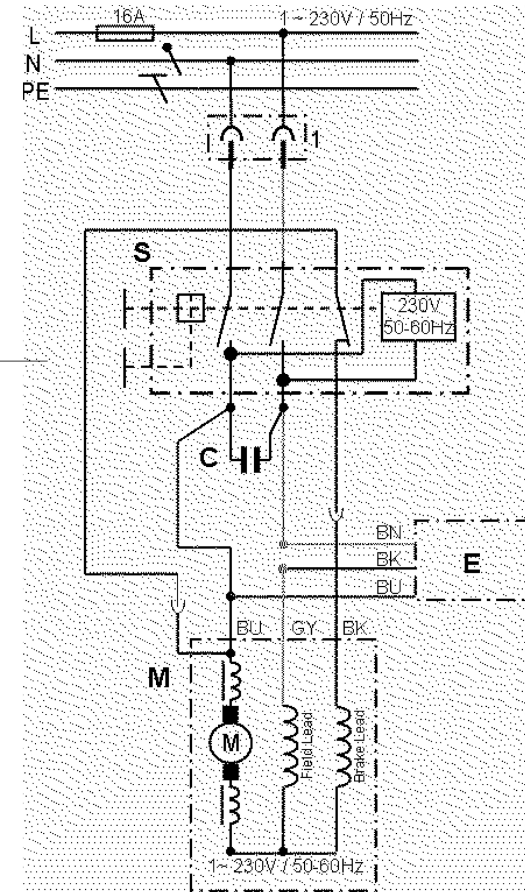

Symbol	Bedeutung der Kurzzeichen	Meaning of the symbols
C	Kondensator	capacitor
E	Elektronik-Baustein	Electronic unit
M	Motor	Motor
S	Schalter	Switch
BK	Schwarz	Black
BN	Braun	Brown
BU	Blau	Blue
GY	Grau	Grey

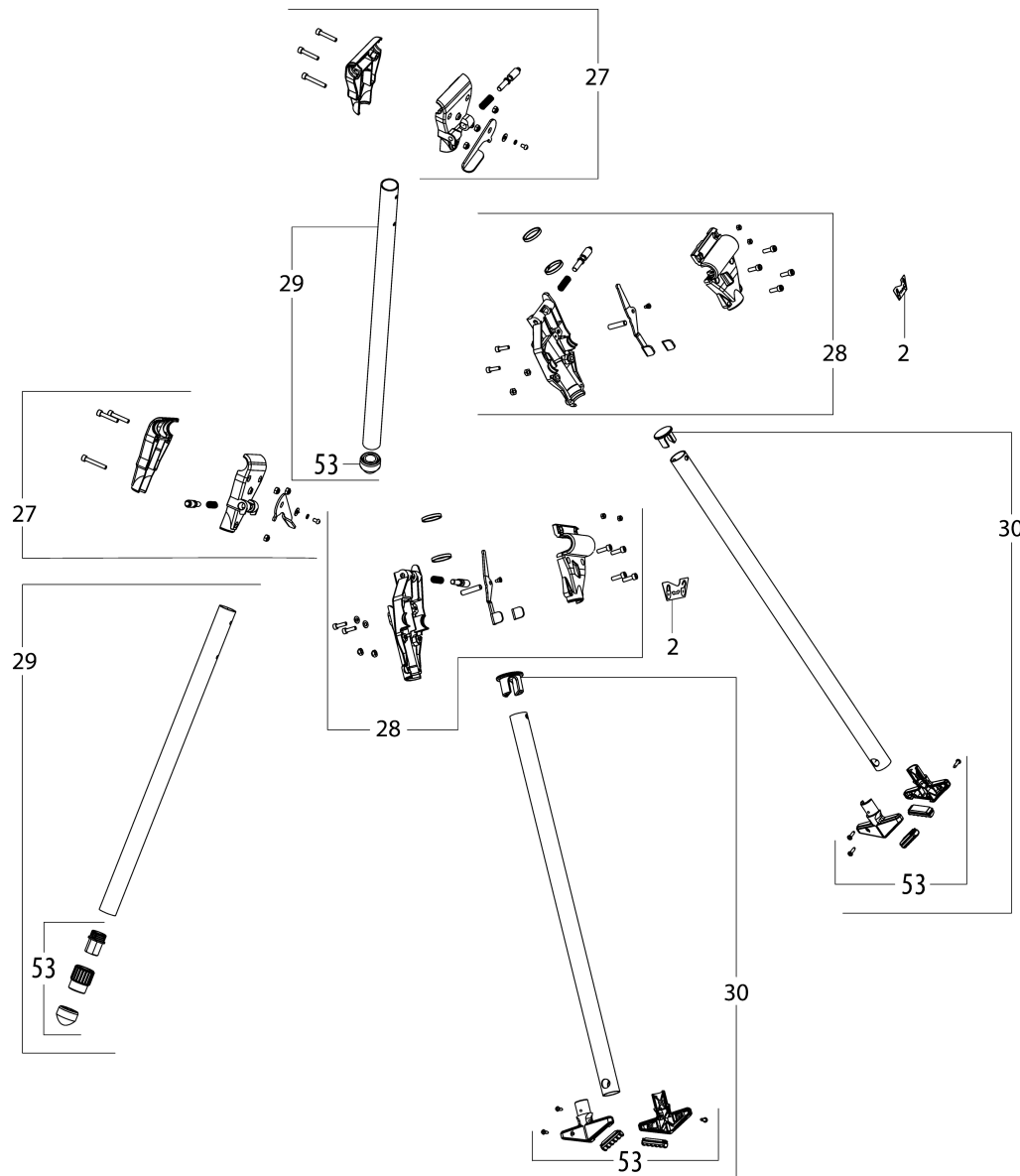

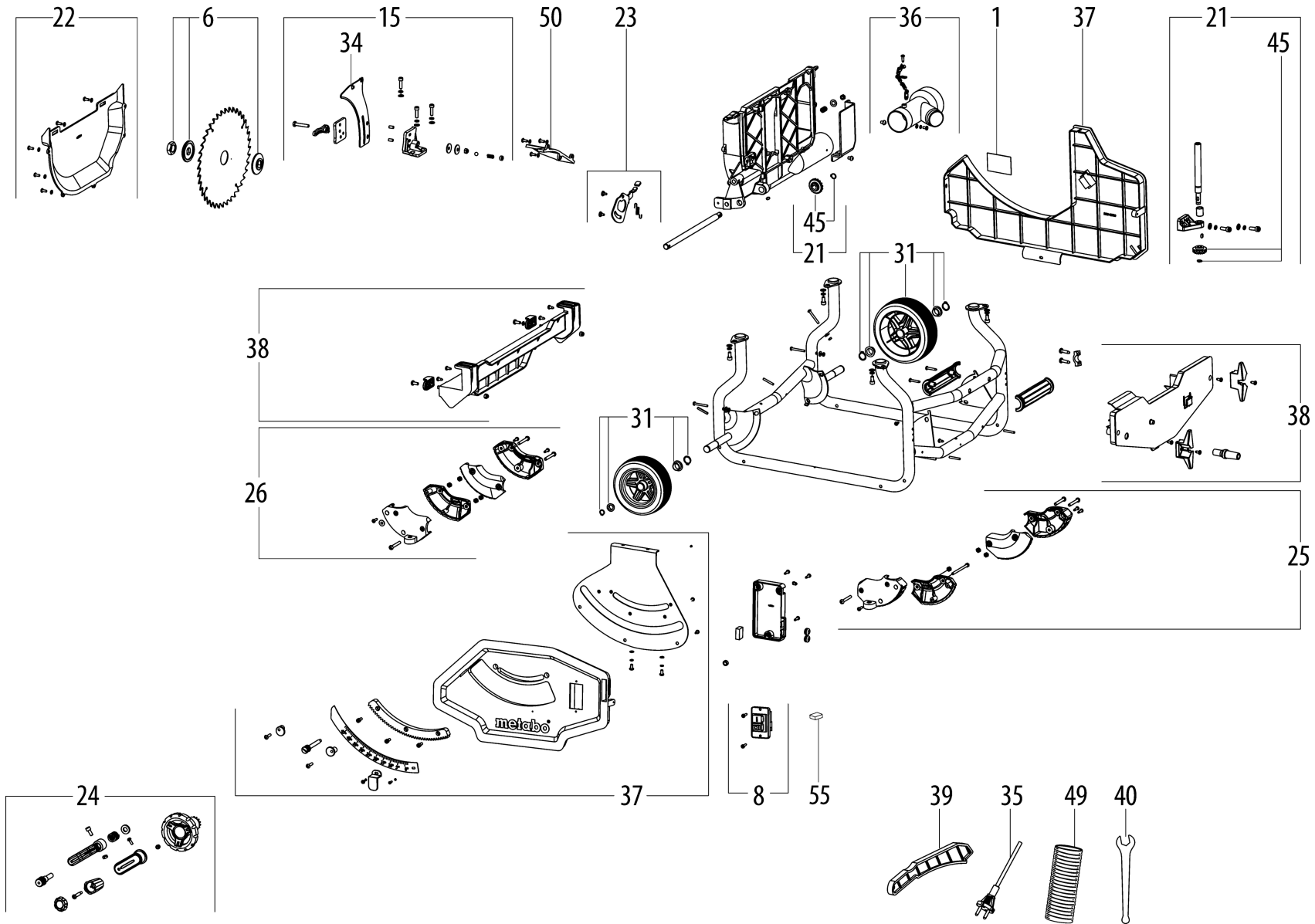
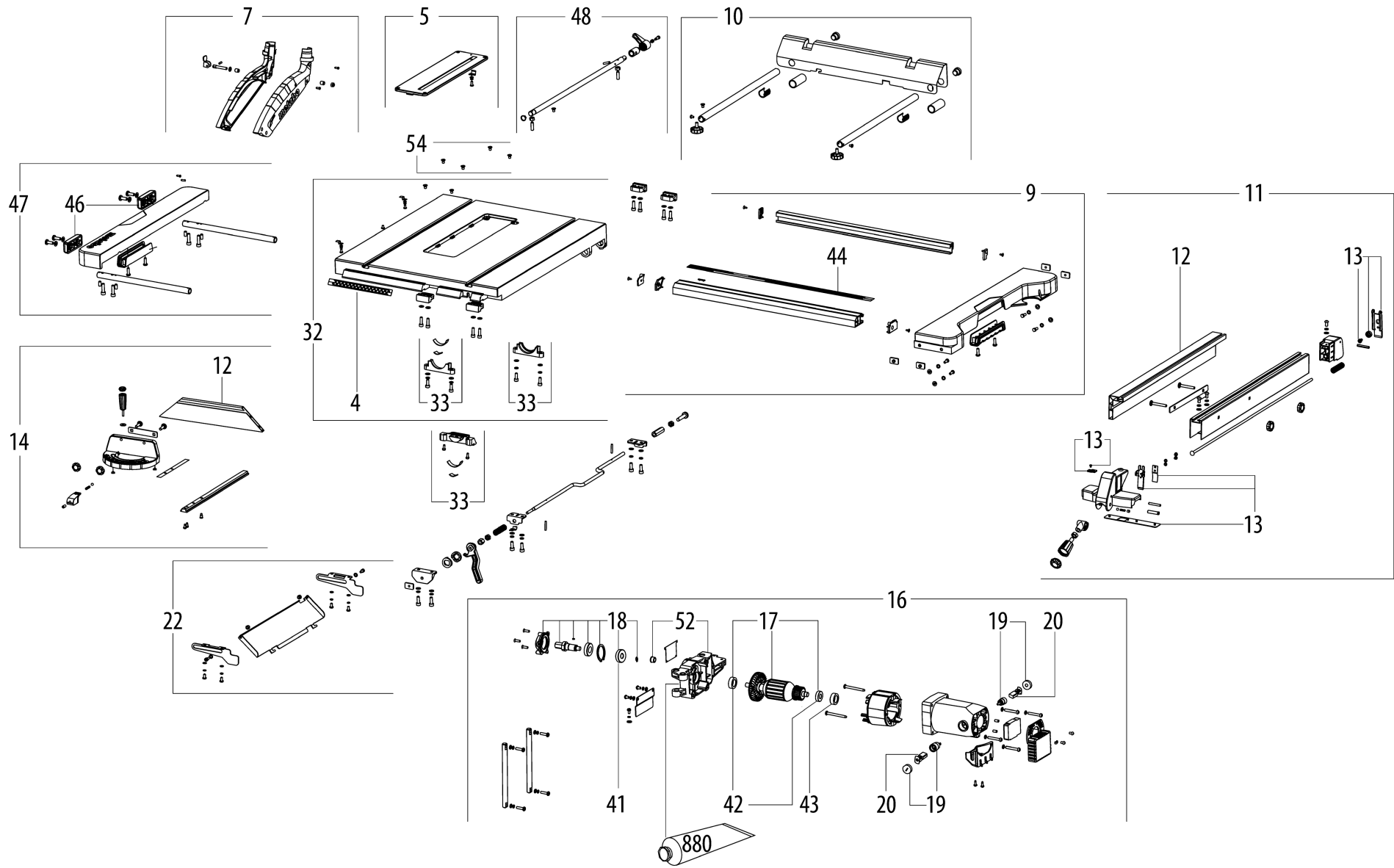

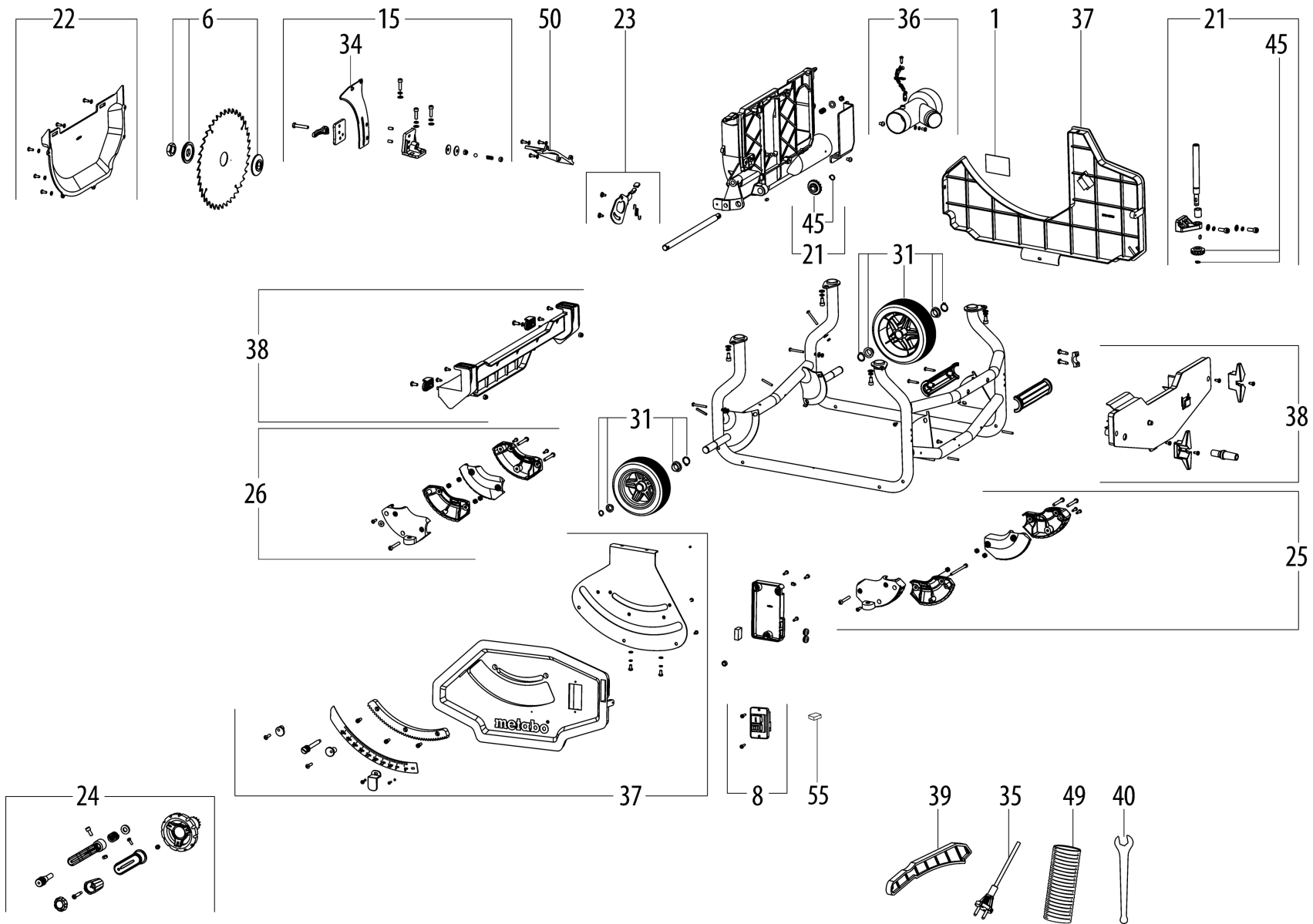

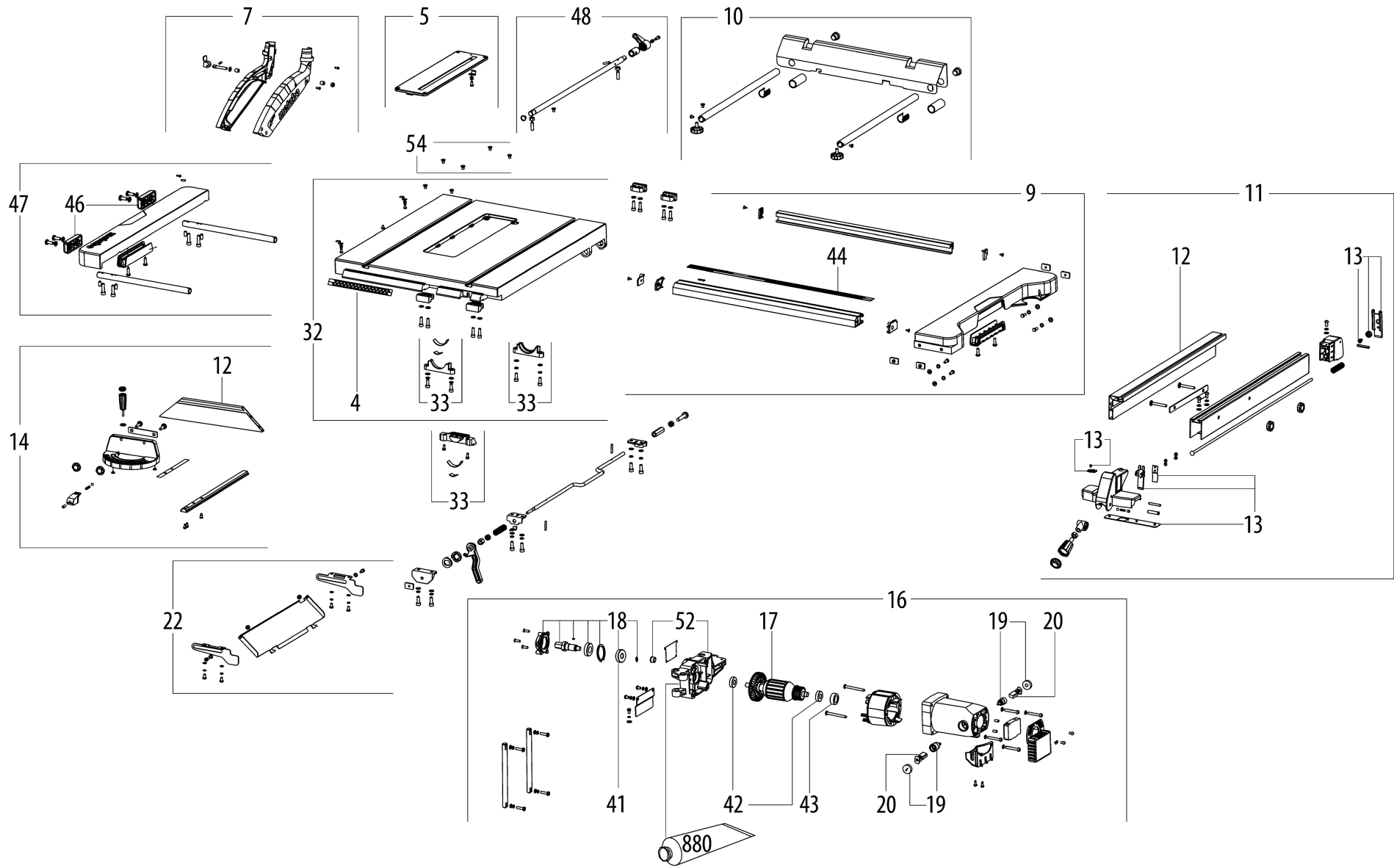

Pozícia	Počet	Typové číslo	Označenie	PG
1	1	338061940	Typovy stitok	11
2	1	338123720	Hinweisschild Funktionserklaerung Lock	11
4	1	338125170	STUPNICA	11
5	1	316057510	Tischeinlage vollst.	24
6	1	316057520	Saegeblattflansch vollst.	19
7	1	316057530	OCHRANNY KRYT KOMPL.	25
8	1	343409960	Schalter	26
9	1	316057540	Tischverbreiterung vollst.,rechts	41
10	1	316057550	Tischverlängerung vollst.	33
11	1	316057560	Parallelanschlag vollst.	37
12	1	316057570	(Hilfs-) Anschlag vollst.	30
13	1	316057580	Parallelanschlag vollst. (Klemmeinheit)	18
14	1	316057590	Winkelanschlag vollst.	31
15	1	316057600	DRZIAK STIEPACEHO KLINU UPLNY	27
16	1	316057610	Motor vollst.	58
17	1	316057620	Anker vollst.	41
18	1	316057630	Getriebe vollst.	29
19	1	343001260	Kohlehalter	17
20	1	343001270	Kohlebürstensatz	17
21	1	316057640	Hoeheneinstellung vollst.	24
22	1	316057650	OCHRANA LISTU cpl.	26
23	1	316057720	Spindelstopp vollst.	17
24	1	316057660	Handrad vollst.	23
25	1	316057670	Fuss vollst.,rechts	18
26	1	316057680	Fuss vollst.,links	18
27	1	316052530	Gelenkarm links,vollst.	35
28	1	316052540	Gelenkarm rechts,vollst.	36
29	2	344099460	Bein, verstellbar	27
30	2	316052570	Bein vollst	29
31	2	316052580	Rad vollst.	26
32	1	316057690	Tisch vollst.	51
33	1	316057700	Fuehrung Schwenkrahmen vollst.	20
34	1	339136290	ROZPERNY KLIN	24
35	1	344499860	Kabel m.Stecker	28
36	1	316057710	Absaugstutzen vollst.	18
37	1	316057730	Gehaeuse vollst. (Vord.+Rücks.)	34
38	1	316057740	Gehaeuse vollst. (Seitenteile)	29
39	1	343433180	Schiebestock (Kunststoff)	15
40	1	341210480	Schluessel	13
41	1	341161760	Zahnrad	25
42	1	320050890	Kugellager Set	19

Pozícia	Počet	Typové číslo	Označenie	PG
43	1	344114030	GUMENE PUZDRO	11
44	1	338125180	STUPNICA	15
45	1	340033720	Tellerrad Satz	18
46	1	343431310	Standfuss	14
47	1	316057750	Tischverbreiterung vollst.,links	33
48	1	316057760	Arretierung vollst.	21
49	1	343437120	NASAVACIA HADICA	28
50	1	344112650	Spanleitstueck	13
52	1	316097280	Getriebeflansch vollst. (f. Motor)	29
53	1	316097240	Fuss vollst.	23
54	4	141112210	ZAPUSTNA SKRUTKA	11
55	1	8050734103	Kondensator	11
880	1	136012860	Getriebefett	17
1001	1	338505650	Verdrahtungsplan	

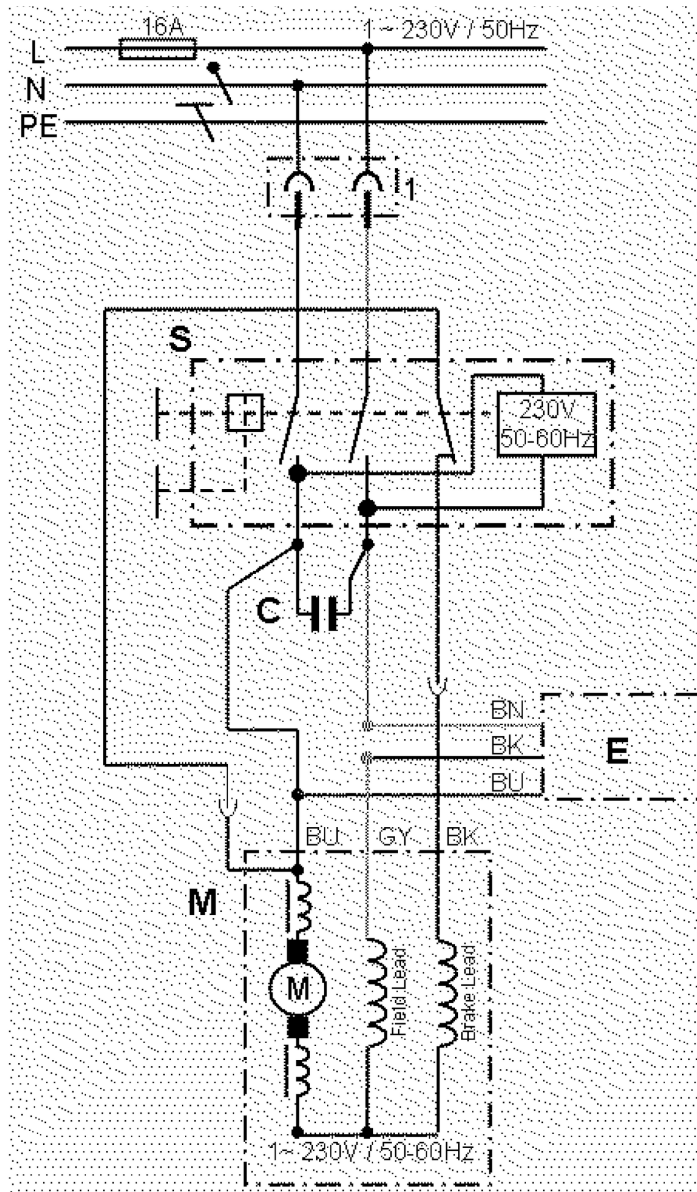

	Bedeutung der Kurzzeichen	Meaning of the symbols
C	Kondensator	capacitor
E	Elektronik-Baustein	Electronic unit
M	Motor	Motor
S	Schalter	Switch
BK	Schwarz	Black
BN	Braun	Brown
BU	Blau	Blue
GY	Grau	Grey