

1001

73

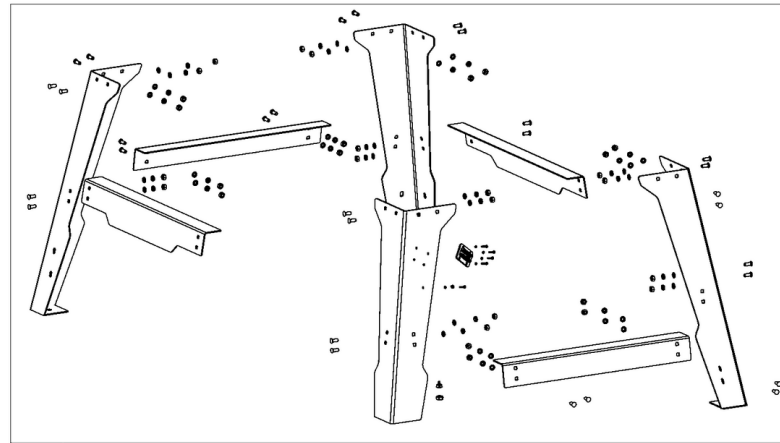

80

81

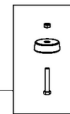

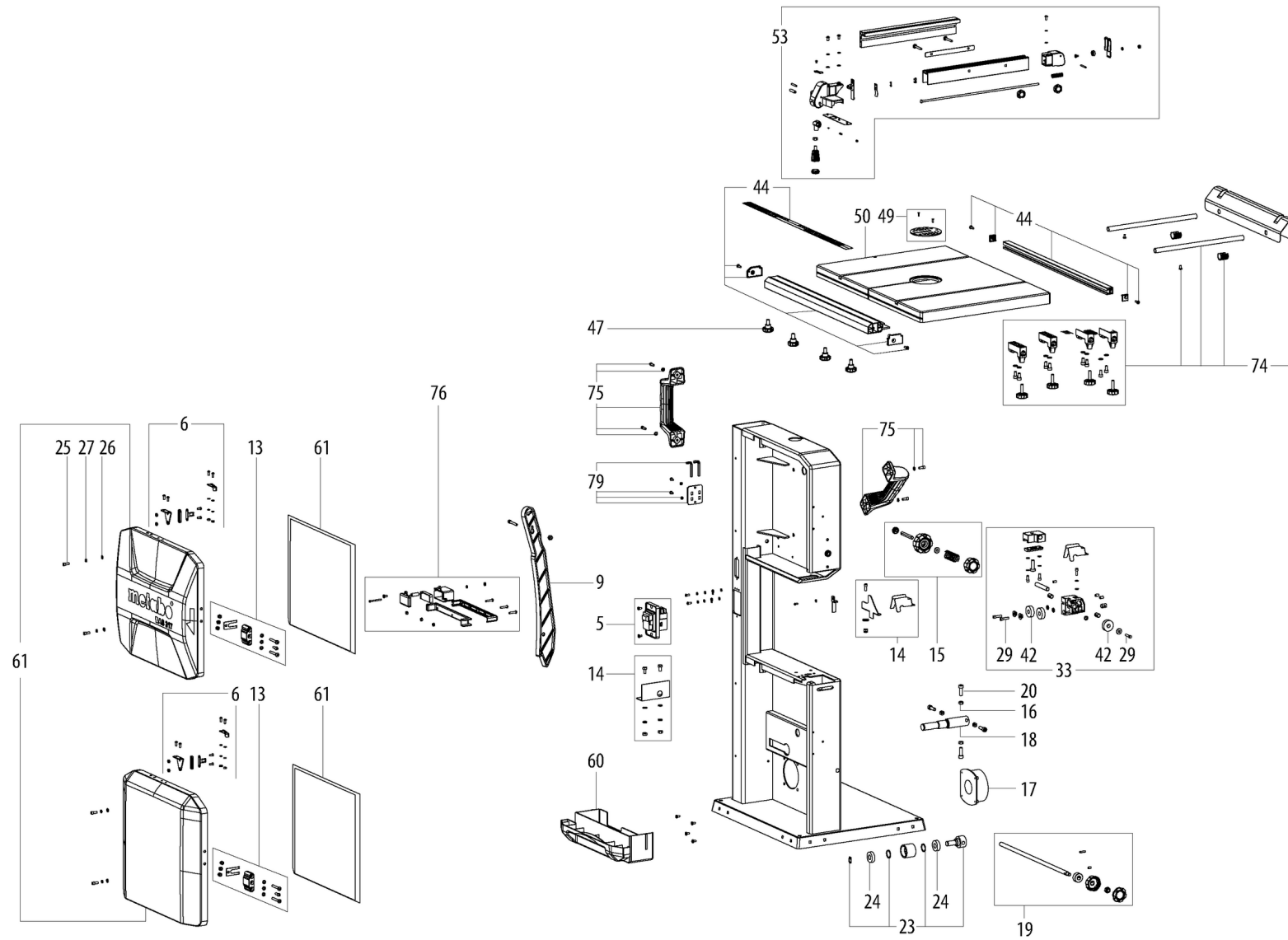

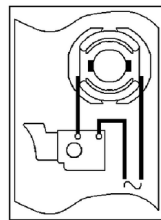
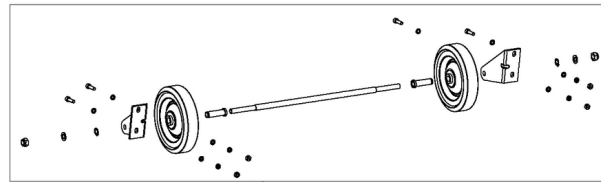

1001

73

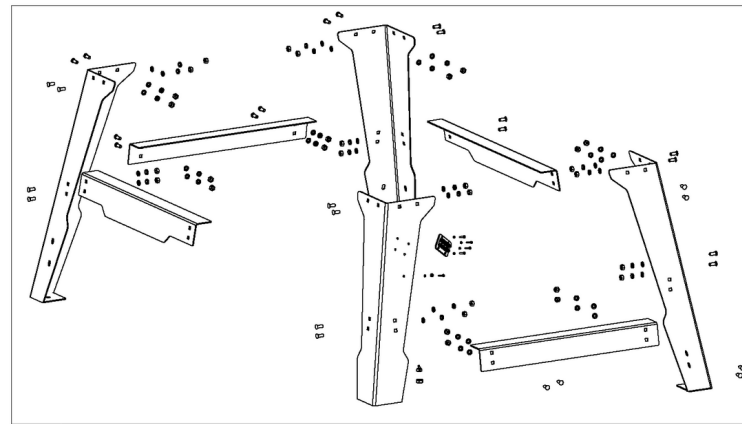

80

81

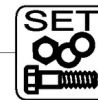

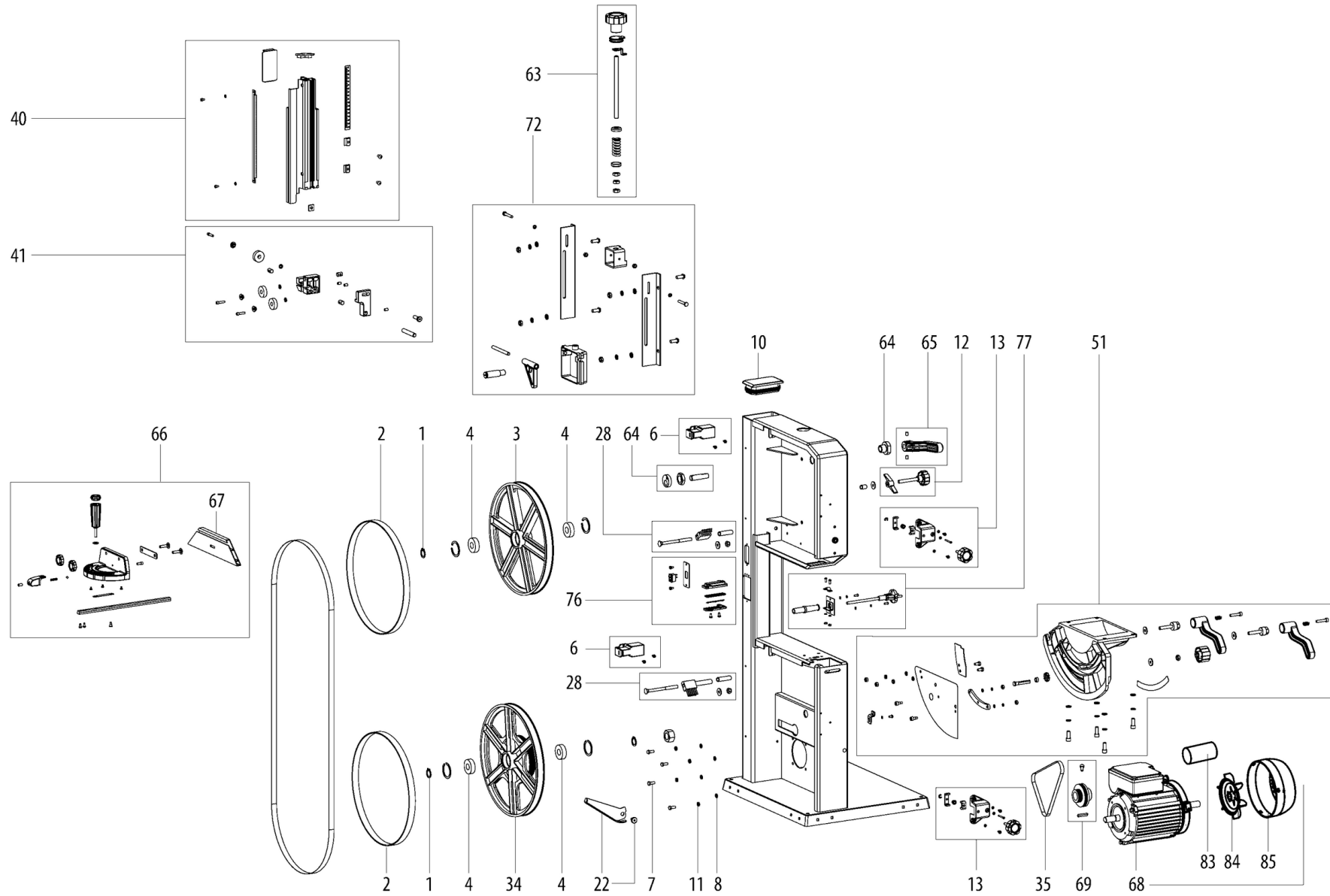

Pozícia	Počet	Typové číslo	Označenie	PG
1	2	141180110	BEZPECNOSTNY KRUZOK	12
2	2	344101930	Bandsaegenbandage	17
3	1	315419740	Bandsaegenrolle oben	35
4	4	143114460	KULA. 17X 40X 12	19
5	1	343411350	VYPINAC	27
6	1	343411470	Sicherheitsschalter vollst.	29
7	4	141113290	6 HRANNA SKRUTKA	11
8	4	141150130	PODLOZKA	11
9	1	343433180	Schiebestock (Kunststoff)	15
10	1	343443710	Abdeckkappe	13
11	4	141155240	PRUZNA PODLOZKA	12
12	2	316095120	(Stell-) Knopf vollst.	17
13	2	341166550	Schliesssystem	22
14	1	316095600	Saagebandschutz vollst.	15
15	1	316095610	Hoehenverstellung vollst.	17
16	4	141130100	6 HRANNA MATICA	11
17	1	343443820	Absaugadapter	16
18	1	341519690	Lagerbolzen	20
19	1	316095620	Spannvorrichtung vollst.	19
20	4	141124160	Schraube, M6 x 20	12
21	6	141124560	LINSENSCHRAUBE M.KREUZSCHLITZ	11
22	1	339148500	BEZPECNOSTNA PAKA	14
23	1	316095630	Spannrolle vollst.	24
24	1	143111440	GULICKOVE LOZISKO 12X28X8	27
25	4	141113680	VALCOVA SKRUTKA	12
26	4	141190480	PODLOZKA	11
27	4	141150270	PRUZYNY KRUZOK	11
28	1	344081750	Buerstenleiste vollst.	14
29	4	141113710	VALCOVA SKRUTKA	12
30	1	141130200	6 HRANNA MATICA	13
31	1	141180110	BEZPECNOSTNY KRUZOK	12
33	1	316095640	Dreirollenfuehrung unten vollst.	27
34	1	316095650	SPODNA KLADKA PASOVEJ PILY cpl.	34
35	1	7233190017	KEILRILLENRIEMEN 4 PJ 610	24
40	1	316095660	Saagebandschutz vollst.	29
41	1	316095670	Dreirollenfuehrung oben vollst.	27
42	6	143111090	GULICKOVE LOZISKO 10X30X9	24
44	1	316095680	Fuehrungsprofil vollst.	33
47	4	343443770	Fluegelschraube	16
49	1	316095690	Tischeinlage vollst.	11
50	1	316095700	Bandsaegentisch vollst.	63

Pozícia	Počet	Typové číslo	Označenie	PG
51	1	316095710	Tischverstellung vollst.	50
53	1	316095720	Parallelanschlag vollst.	40
60	1	343443830	Spänekasten	26
61	1	316095730	Tuere vollst.	41
62	1	343443720	HVIEZDICOVA SKRUTKOVA RUKOVAT	19
63	1	316095740	Einstellvorrichtung vollst.	23
64	1	316095750	Schnellentspannung	26
65	1	341166470	OBSLUZNA PAKA	19
66	1	316095760	Winkelanschlag vollst.	29
67	1	316095770	PREDSADKOVY PROFIL cpl.	21
68	1	317004790	Motor vollst.,230V	59
69	1	316095780	KLINOVA DRAZKOVA REMENICA cpl.	29
72	1	316095790	Rollenfuehrung vollst.	30
73	1	316095800	Fahrwerk vollst.	34
74	1	316095110	Tischverbreiterung vollst.	31
75	2	316095130	RUKOVAT cpl.	25
76	1	316095810	LED SVIETIDLO cpl.	20
77	1	344530940	Kabel vollst.	25
79	1	316095820	UPNUTIE NASTROJA cpl.	12
80	1	316095830	Maschinenständer vollst.	52
81	1	316095840	Schraubenset vollst.	27
82	1	338067100	Leistungsschild 19009000 BAS 318 Pre WNB	11
83	1	343255130	KONDENZATOR	23
84	1	343445370	KRIDLO VENTILATORA	18
85	1	339204860	Abdeckung	19
1001	1	338506180	Verdrahtungsplan	



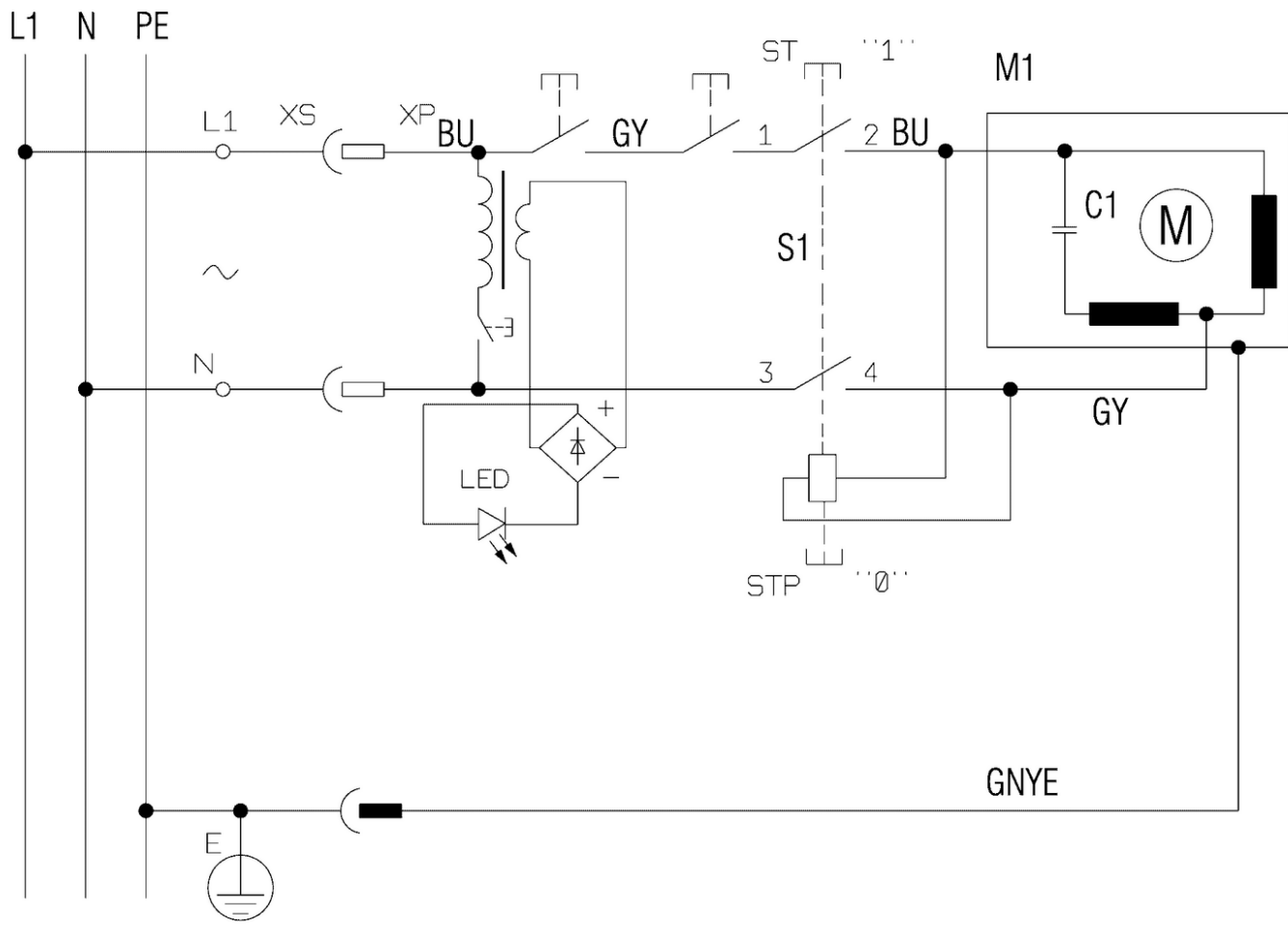

M1: induction motor 220-240V / 50-60Hz  
S1: KJD12  
C1: 22 $\mu$ F